

# Alumacs® 10K Shoring System

The lightweight, high-strength aluminum shoring system.

AlumaSystems

The Alumacs® 10K Shoring System incorporates lightweight aluminum frames and high grade steel cross braces and jacks. These combine to give savings in labor costs and maximize load bearing capacity. Full compatibility with Aluma Systems' extensive range of Aluma Beams® allows this system to meet the needs of the most demanding projects.

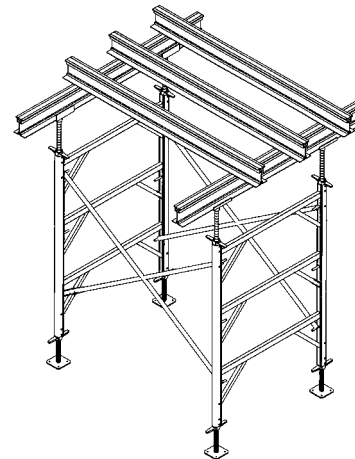

## Product Description

Alumacs® 10K Shoring System has been specifically designed to satisfy a growing market demand for a lighter more productive, vertical shoring system. These frames are manufactured from a high strength primary extrusion aluminum alloy and have a higher load to weight ratio than any steel shoring system currently on the market.

Equipped with a full range of accessories that

include Extension Staffs, Saddle Beams, Top and Base Jacks, J-Heads and a number of brace sizes, the Alumacs® 10K Shoring System is certain to meet most shoring needs. Furthermore, our extensive range of Aluma Beam® and Stringers maximizes the flexibility of the system as well as its load bearing capacity. The frames are rated at a maximum loading of 10 Kips per leg with a factor of safety of 2.5:1.

The Alumacs® 10K Shoring System conforms to all shoring regulations, including CSA, CAL-OSHA AND ANSI.

### Cross Braces and Sizes

Frame stud spacing is 0.61m (2'0") on center. Refer to bracing chart for correct procedure\*.

Standard braces are available for tower widths of 5'0" (1.52m), 7'0" (2.13m), 10'0" (3.04m) other sizes may be available on inquiry.

### Features

- Lightweight aluminum construction reduces labor costs
- Steel braces and screwjacks for increased durability and strength
- Compatible with the full range of Aluma Beam® and Stringer
- Modular design increases flexibility and simplicity

\* Consult our Engineering Department for assistance in the application of this product.

### Warning, Limitation of Aluma Systems Liability:

This bulletin is intended only for general information on the Alumacs® 10K Shoring System. This product is only to be used for the purpose for which it is intended and only per the load capacities as established by Aluma Systems. This product must not be used when damaged and must be in fully functional condition. This product must be inspected by the user before use and properly stored, maintained and repaired. This product must not be misused nor overloaded.

Frames

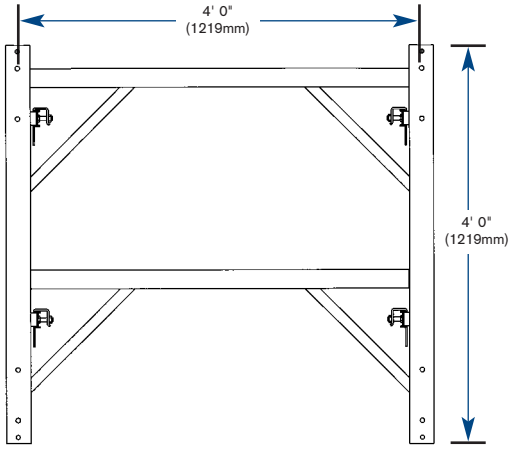

**4'0" x 4'0" Frame**

ITEM NO.	WEIGHT - LB. (KG)
257	23 (11)

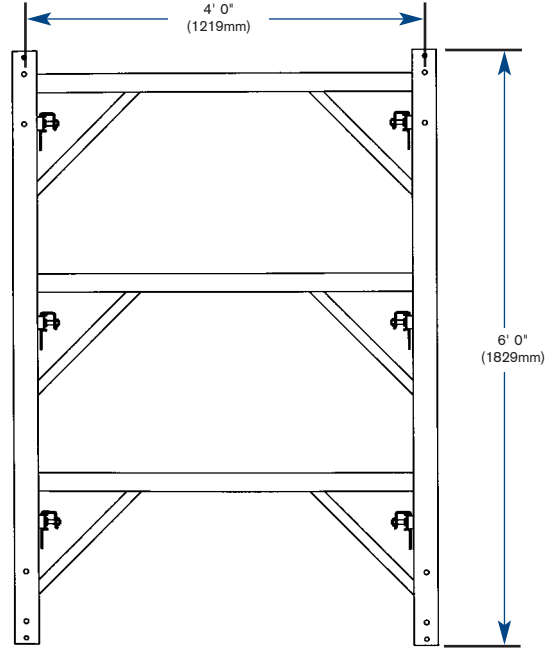

**4'0" x 6'0" Frame**

ITEM NO.	WEIGHT - LB. (KG)
258	31 (14.2)

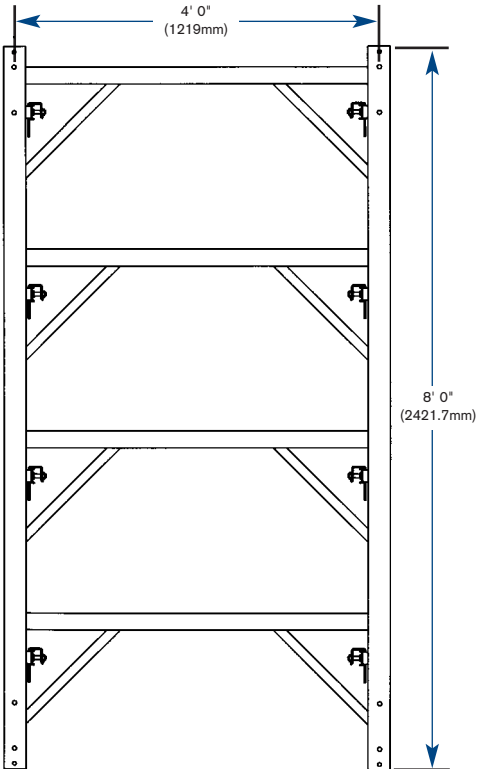

**4'0" x 8'0" Frame**

ITEM NO.	WEIGHT - LB. (KG)
259	48 (21.77)



**Base Plate**

ITEM NO. WEIGHT - LB. (KG)  
 265 8.1 (3.7)  
 DESCRIPTION  
 Base plate can be attached to either the screwjack (625) or to the frame leg with toggle pin (549). Used as flat plate head, it can be bolted to Aluma Stringer with Aluma Bolts.

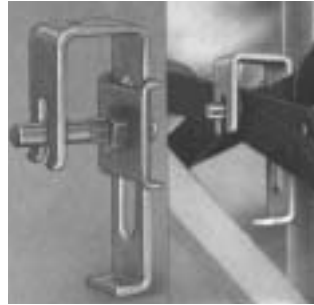

**Cross Brace Lock Assembly**

ITEM NO. WEIGHT - LB.(KG)  
 2271 0.74 (0.3)  
 DESCRIPTION  
 A positive gravity lock with free travel in aluminum track. Track (522) secured to frame leg with fillet weld. The cross braces are supported on a special steel pin (983). Brace sets of two or four are restrained from excessive lateral movement by the lock. A special washer (984) in assembly, positions the pin location and locks the jam nut (958).



**Connector Pin**

ITEM NO. WEIGHT - LB.(KG)  
 263 0.9 (0.4)  
 DESCRIPTION  
 A 6" x 0.5" diameter (152mm wide x 13mm) "U" pin to connect stacked frames used with Frame Connector 613. Two different sized legs provide positive penetration, stops on rods prevent jamming.



**Toggle Pin**

ITEM NO. WEIGHT - LB.(KG)  
 4352 0.4 (0.2)  
 DESCRIPTION  
 A 0.325" x 4" long (9.5mm diameter x 200mm) pin with a 1" (25mm) return. For use with items 625, 535, 621. This pin is non-load bearing.



**Frame Connector**

ITEM NO. WEIGHT - LB.(KG)  
 261 0.9 (0.4)  
 DESCRIPTION  
 Tubular internal connector 7.5" (200mm) long with chamfered ends. Frame leg ends bear on a tubular collar 0.5" (13mm) long. The holes accept the connector pin (263).



**"J" Head**

ITEM NO. WEIGHT - LB.(KG)  
 239 8.1 (3.7)  
 DESCRIPTION  
 Steel "J" Head with a 3" (76mm) collar, secures to screw jack (625) with toggle pin (549) - which is non load bearing. Both Aluma Beams® and Stringers are accepted and centrally located, therefore eliminating the need for blocking. Aluma Stringers and Aluma Beams® can be locked to the "J" Head with Aluma bolts or remain loose for ease in stripping.

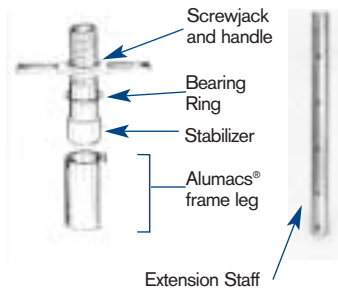

**Screwjack, Handle / Nut**

ITEM NO. WEIGHT - LB.(KG)  
 521 9.0 (4.2)  
 DESCRIPTION  
 Hollow steel tube (50,000 psi yld 34.5 MPa)

**Screw Handle**

High capacity, fine adjustment, 1" (25mm) nut with double 4" (100mm) handles to suit 521.

**Extension Staff**

ITEM NO. WEIGHT - LB.(KG)  
 610 0.9 (0.4)  
 611 1.4 (0.6)  
 DESCRIPTION  
 Tubular aluminum with holes at 6" increments. Sizes available: 29" (610) and 47" (611)



**Alumas® Clamp**

ITEM NO. WEIGHT - LB.(KG)  
 1606 4.5 (2.04 )  
 DESCRIPTION  
 A swivel clamp that attaches to the Alumas® Frame leg and a 1.9" (48mm) tube. Used when additional lacing and bracing is required on towers three frames and higher. Finish - Zinc Plated

## Load Charts

### Alumacs Frame Leg Capacity

Frame Height	Total Screwjack Extension (A+B)	Inter-Frame Bracing?	NUMBER OF TIERS							
			1		2		3		4	
			kips	kN	kips	kN	kips	kN	kips	kN
4' (1.2 m)	48"	no	10.00	44.5	9.26	41.2	7.80	34.7	7.10	31.6
	1219 mm	yes	--	--	10.65	47.4	8.97	39.9	8.16	36.3
	36"	no	11.50	51.2	10.36	46.1	9.10	40.5	8.17	36.3
	914 mm	yes	--	--	12.43	55.3	10.92	48.6	9.80	43.6
	24"	no	13.20	58.7	12.30	54.7	11.00	48.9	9.70	43.1
	610 mm	yes	--	--	16.00	71.2	13.75	61.2	12.12	53.9
	12"	no	15.60	69.4	13.82	61.5	12.52	55.7	10.9	48.5
	305 mm	yes	--	--	17.96	79.9	16.10	71.6	14.17	63.0
6' (1.8 m)	48"	no	8.40	37.4	7.83	34.8	7.40	32.9	7.10	31.6
	1219 mm	yes	--	--	9.00	40.0	8.51	37.9	8.16	36.3
	36"	no	10.00	44.5	8.86	39.4	8.40	37.4	8.17	36.3
	914 mm	yes	--	--	10.63	47.3	10.28	45.7	9.80	43.6
	24"	no	11.20	49.8	10.40	46.3	10.00	44.5	9.70	43.1
	610 mm	yes	--	--	13.50	60.0	12.50	55.6	12.12	53.9
	12"	no	13.40	59.6	11.82	52.6	11.52	51.2	10.90	48.5
	305 mm	yes	--	--	15.36	68.3	14.97	66.6	14.17	63.0
8' (2.4 m)	48"	no	7.56	33.7	7.05	31.3	6.66	29.6	6.39	28.4
	1219 mm	yes	--	--	8.10	36.0	7.66	34.1	7.34	32.7
	36"	no	9.00	40.1	7.97	35.5	7.56	33.7	7.35	32.7
	914 mm	yes	--	--	9.57	42.6	9.25	41.1	8.82	39.2
	24"	no	10.08	44.8	9.36	41.7	9.00	40.1	8.73	38.8
	610 mm	yes	--	--	12.20	54.0	11.25	50.0	10.91	48.5
	12"	no	12.06	53.6	10.64	47.3	10.37	46.1	9.81	43.7
	305 mm	yes	--	--	13.82	61.5	13.47	59.9	12.75	56.7

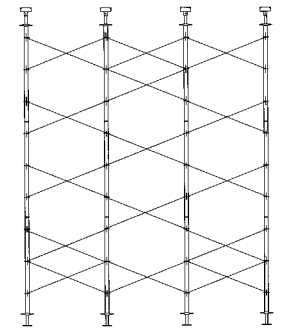
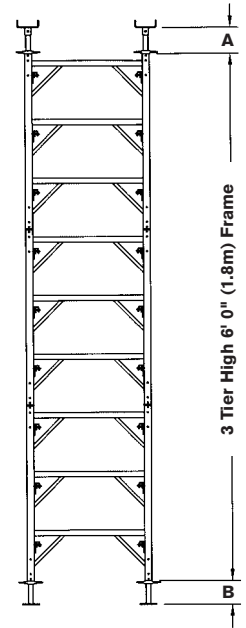

Side View Showing Inter-frame Bracing

Note: 1. Safety factor: 2:5:1

2. Total screwjack extension is sum of top screw extension plus bottom screw extension lengths.

3. Loading stated is vertical load only in 1000's of lbs per leg or kN/leg.

4. Loading is for complete braced towers, not free-standing frames.

Note: For other Frame combinations, consult Aluma Systems Engineering Department.

Consult our Engineering Department for assistance in the application of these accessories. Illustrations are not drawn to scale. All dimensions nominal.

### Contact Us:

Visit our website at  
[www.aluma.com](http://www.aluma.com)

**Aluma Systems  
Canada Inc.**  
55 Costa Road  
Concord, Ontario  
Canada L4K 1M8

T : (905) 669-5282  
F : (905) 660-8045

**Aluma Systems  
USA Inc.**  
2915 Sunrise Avenue  
Las Vegas, Nevada  
USA 89101

T : (702) 866-6513  
F : (702) 866-2620

**Aluma Systems  
International, Inc.**  
55 Costa Road  
Concord, Ontario  
Canada L4K 1M8

T : (905) 669-5282  
F : (416) 736-2924