

# Crane Set Forming System

Top-Quality Modular Forming System

AlumaSystems



The completely modular Crane Set System offers contractors standard panel and filler sizes to meet all demanding forming requirements.

## Product Description

It's easy to testify to the advantages of investing in a top quality forming system when the completely modular Crane Set System is being discussed. It offers contractors standard panel and filler sizes to meet all demanding forming requirements.

The system's frames are 3-inch steel channels 1 ft. on center designed for 1,200 psf at 2:1 safety factor with a wood face (steel is 1,500 psf, sale only). This allows higher pour rates which reduces labor, crane time, and pumping costs.

Aluma Systems' rigid quality control assures consistent manufacturing tolerances. This means no shims at joint bolts are required. The labor to assemble gangs is minimized and the straight walls produced reduce finishing costs.

The Aluma Crane Set System is proving ideal for

water and sewage treatment plants, power plants, bridges, dams, high rises, and many other types of jobs.

The same components can be used to form straight or curved walls, Y walls, pedestals, battered walls, culverts, columns, haunches, pilasters, etc.

Crane Set System is completely compatible with most of Aluma Systems' other forming systems – Hand-Set System and Custom Systems – without special transition panels and expensive hardware.

Standard Crane Set sizes are 1 ft., 2 ft., 3 ft., and 4 ft. in height and 2 ft. 30 in., 3 ft., 4 ft., 5 ft., 6 ft. and 8 ft. in length. Aluma Systems offers a 3/4 in. HDO plywood face for a high quality concrete finish. The Aluma Crane Set System features continuous edge support of forming

surface material which gives better results than plywood attach tabs. Standard steel fillers from 2 to 18 in. eliminate the need for costly, job-built fillers.

Aluma System's Bolted Waler System is available in two channel sizes (5 in. and 8 in.) and eight standard lengths from 4 to 16 ft. This provides flexibility in tie locations eliminating interference of spacers in welded walers. The bolted waler also provides the flexibility to be used as a single channel aligner. Positive waler to panel connection is provided by Aluma Systems' Clamp Flat or Waler Clip (rather than bolts).

The Crane Set Forming System conforms to all shoring regulations, including CSA, CAL-OSHA AND ANSI.

## Features

- Low re-use wood forms bolt easily to versatile Crane Set System.
- High walls go up fast with quickly assembled gangs.
- Addition of special splice plates enables Crane Set to handle unique one-sided applications.
- Crane Set works well with Aluma Systems' self-climbing raisers on high rise projects.
- All Aluma Systems Hand-set panels can bolt directly to the heavy duty Crane Set System.
- Lift eyes attach to walers for safer gang movement.

## Warning, Limitation of Aluma Systems Liability:

This bulletin is intended only for general information on the Crane Set Forming System. This product is only to be used for the purpose for which it is intended and only per the load capacities as established by Aluma Systems. This product must not be used when damaged and must be in fully functional condition. This product must be inspected by the user before use and properly stored, maintained and repaired. This product must not be misused nor overloaded.

## Crane Set System Waler, Aligner Accessories

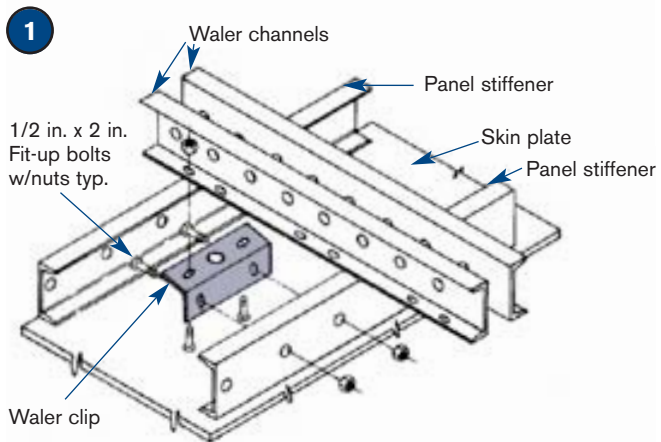
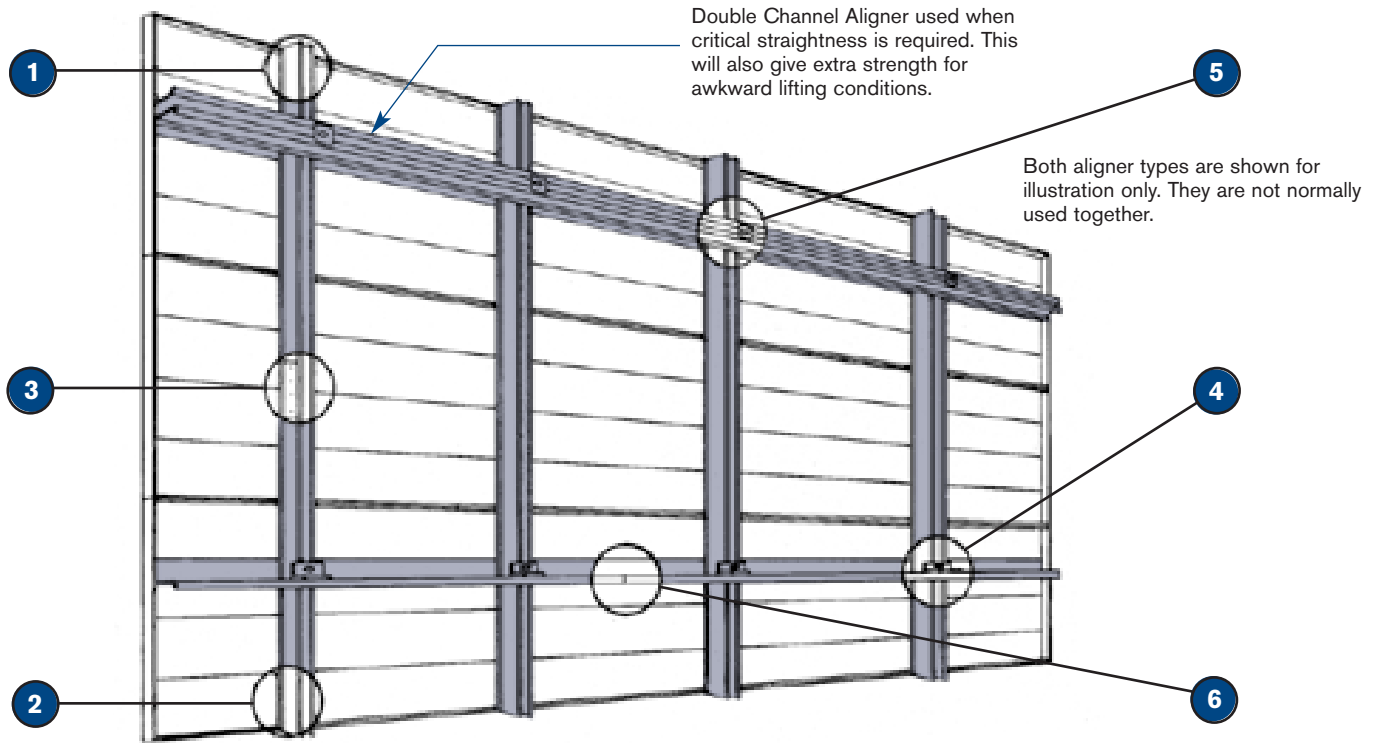

### Channel Connection Using Waler Clip

Provides positive waler to panel connection. Safer than "J" bolts for lifting gangs.

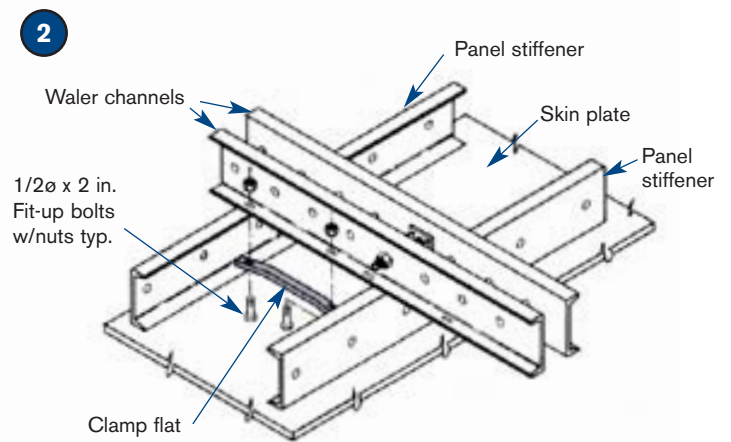

### Waler to Panel Connection with Clamp Flat

Safe positive waler to panel connection. Allows flexibility to move walers horizontally for penetrations, rebar and blockout locations.

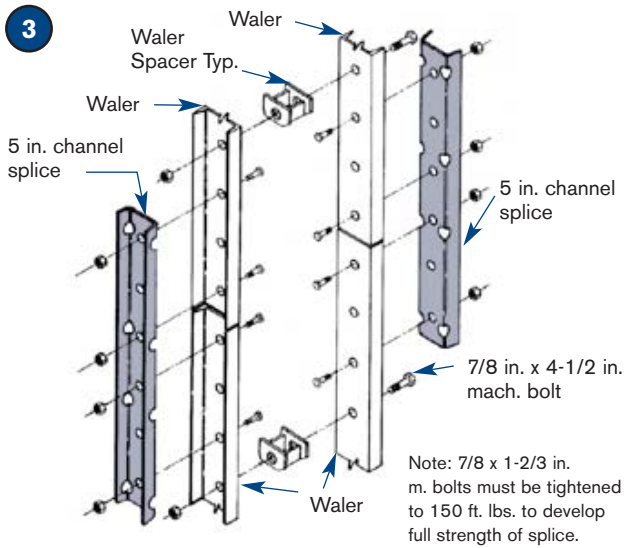

**Waler Splice**

Double channel splice in 5 in. and 8 in. sizes easily extends walers for high walls.

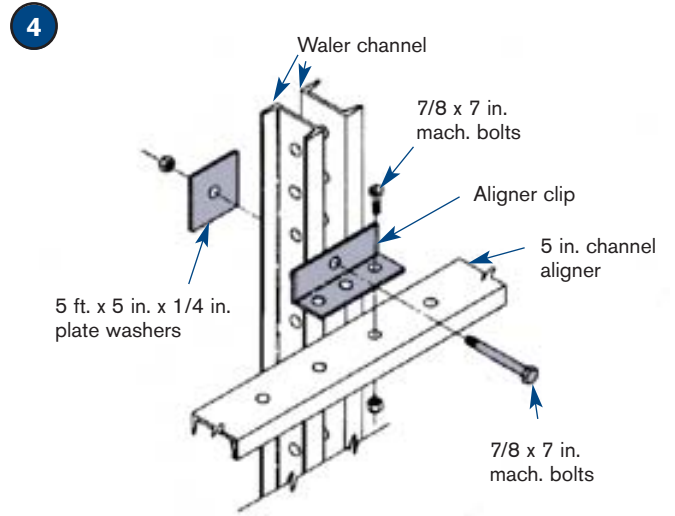

**Single Channel Aligner Connection**

For walls up to 20 ft. high, use one aligner near the top and one near the bottom of the form. Connection should be at every waler.

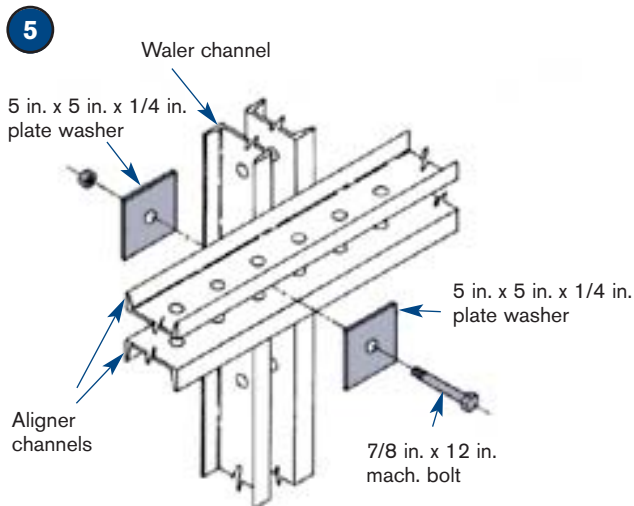

**Double Channel Aligner Connection**

Used when extra strength or straightness is required. Connection should be at every waler.

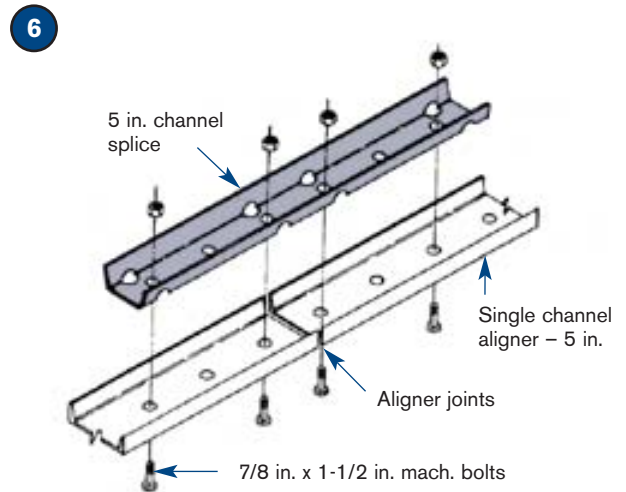

**Channel Splice Connections**

One channel splice is required for aligner splices, but two are needed for waler splices.

8.0k max design pick with 1 in. shackle pin sufficient for approx. 400 sq. ft. with spreader beam

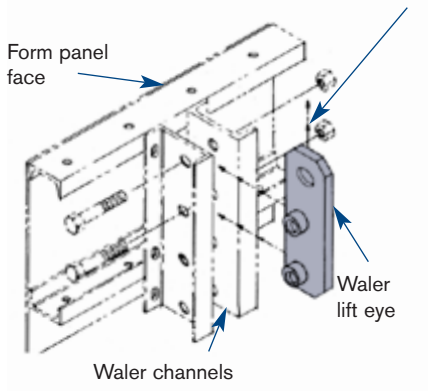

#### Waler Lift Eye

Safe easy lift with one piece of hardware and two bolts.

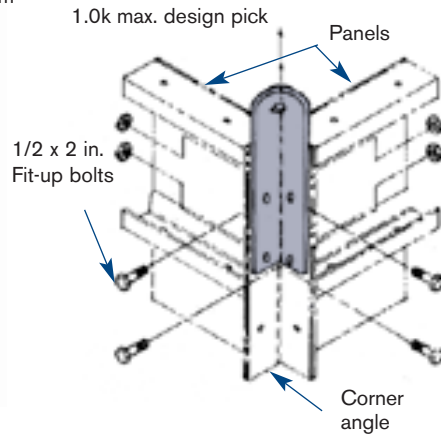

#### Column Lifting Angle

Simplifies crane lifts of complete column forms.

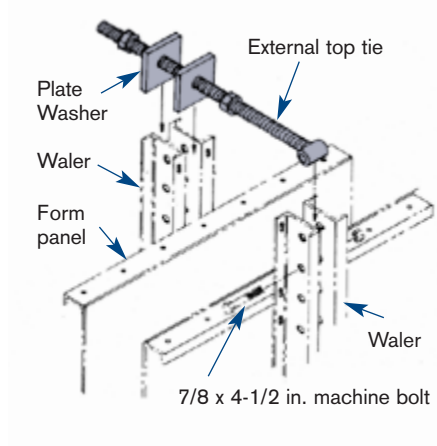

#### Exterior Top Tie Assembly

Eliminates at least one tie in the concrete, so there are fewer holes to patch.

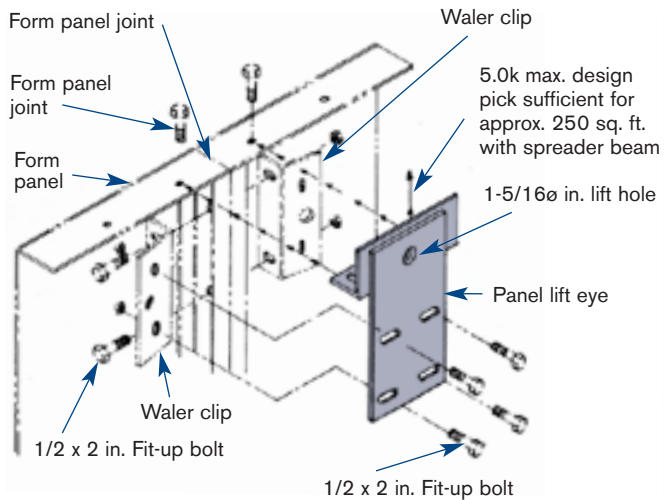

#### Panel Lift Eye

Allows flexibility in selection of pick points. The design pick capacities shown for the panel lift eye and the waler lift eye are for a vertical lift which usually requires the use of a spreader or lift beam.

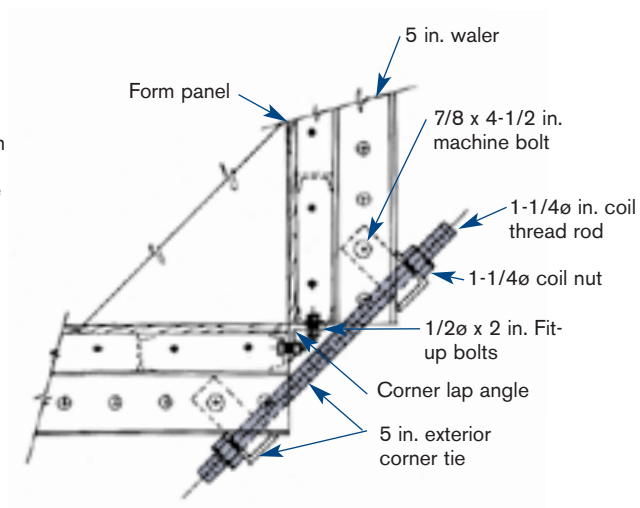

#### Exterior Corner Tie Assembly

Fewer ties are required in horizontal waler applications. Also available for 8" walers.

## Versatile Hardware Simplifies Forming Applications

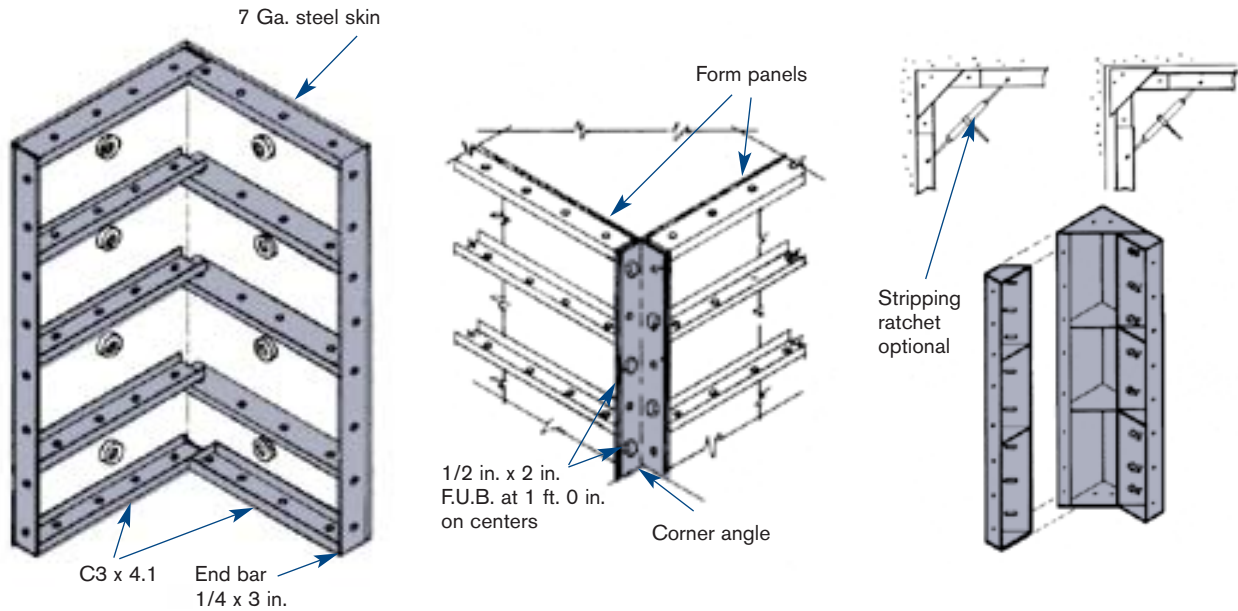

### Rigid Corner Inside

Three standard sizes (6 in. x 6 in., 12 in. x 12 in., and 24 in. x 24 in.) provide durable true corners that reduce labor and finishing costs.

### Corner Angle at Corner Joint

Corner angle can be used to lap previous pour. This saves money by reducing the number of forms required.

### Inside Stripping Corner

Standard 12 in. x 12 in. allows quick stripping between pilasters or intersecting walls. Shafts strip in one piece.

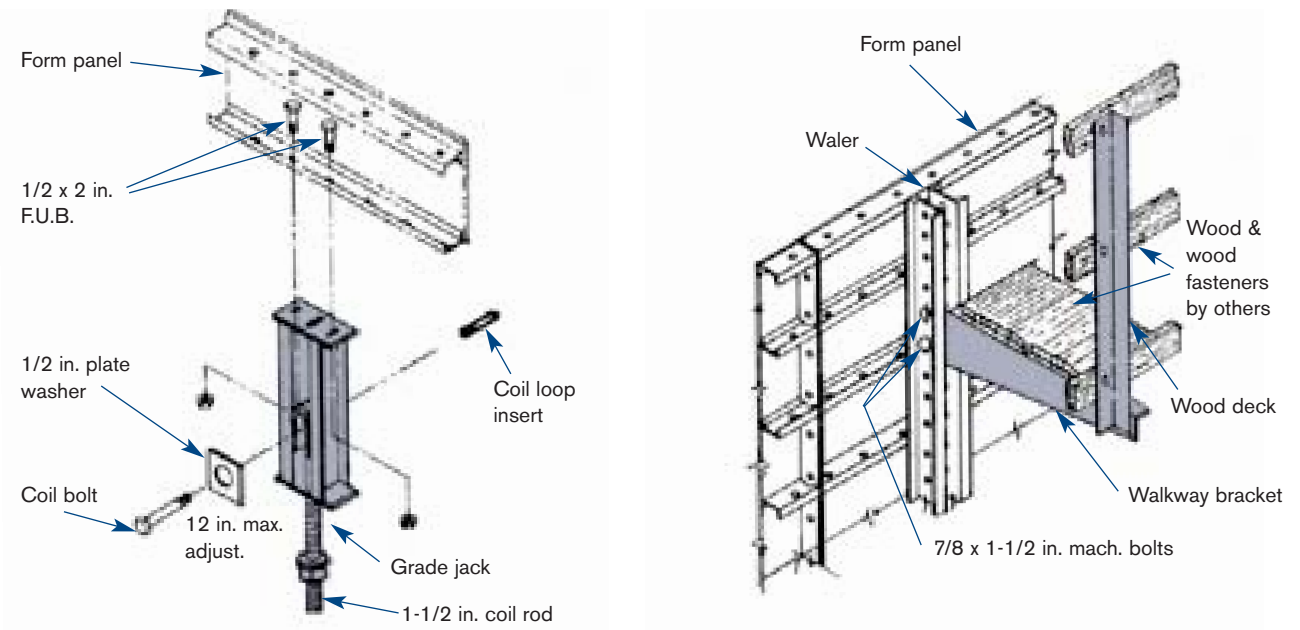

### Grade Jack

Makes it easy to support and grade forms, available in 5K or 15K.

### Walkway Bracket to Waler Connection

Bolts directly to waler or panel reducing scaffolding.

## Standard Crane Set Panels

### 4 x 8 ft. Standard Crane Set Panel

**Face**  
3/4 in. High Density Overlay (HDO)  
Steel, 7 Gauge (sale only)

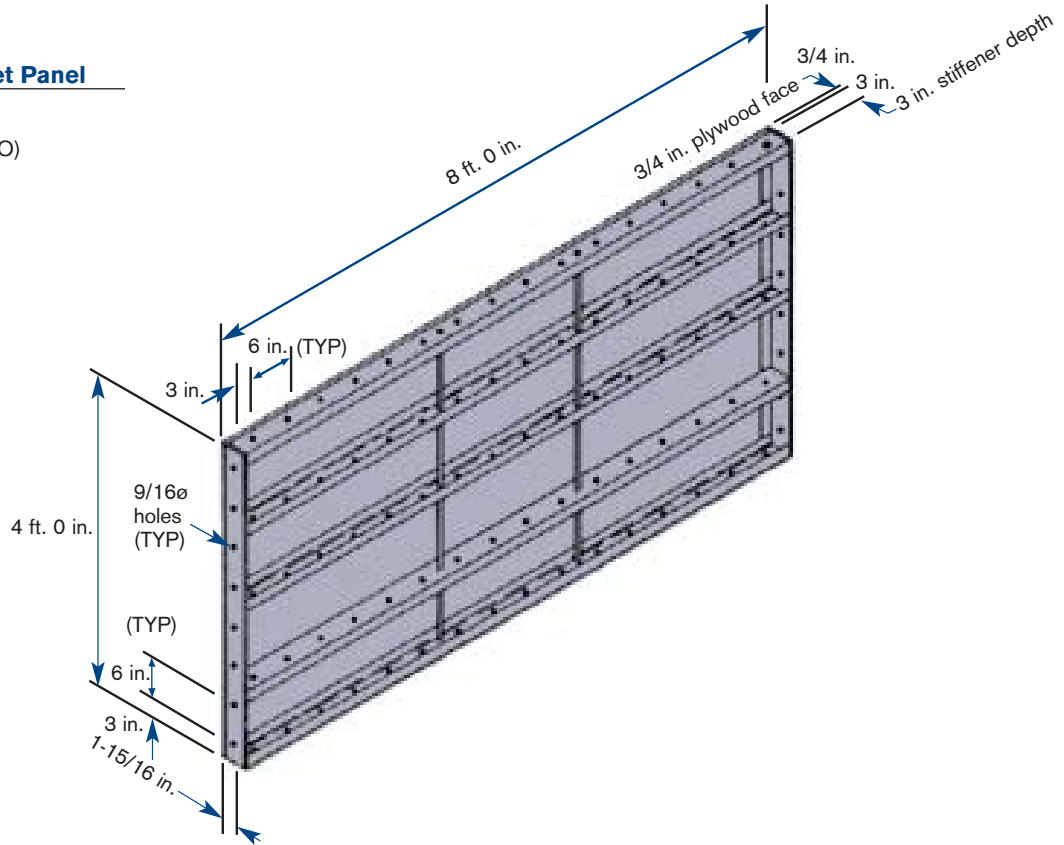

### Crane Set Panel Sizes Wood Face or Steel Face

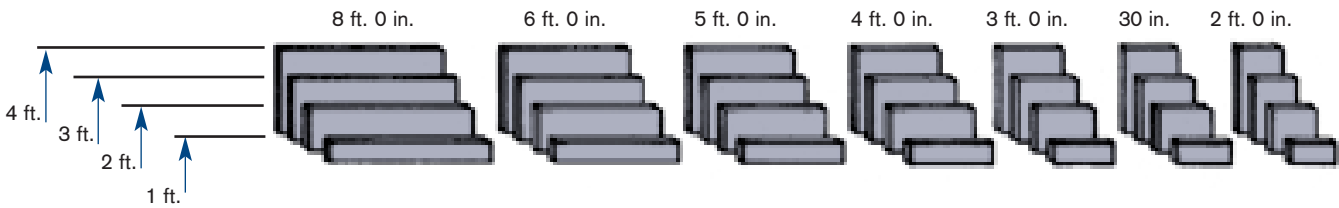

### Fill Panels Steel Face Only

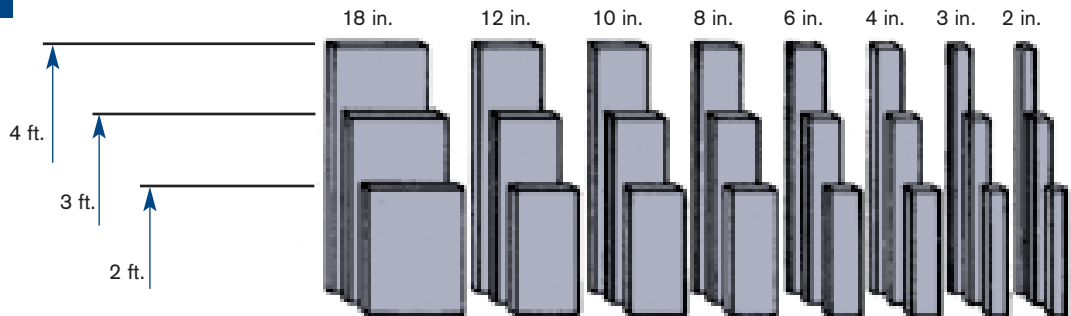

Consult our Engineering Department for assistance in the application of these accessories.  
Illustrations are not drawn to scale. All dimensions nominal.

### Contact Us:

Visit our website at  
[www.aluma.com](http://www.aluma.com)

**Aluma Systems  
Canada Inc.**  
55 Costa Road  
Concord, Ontario  
Canada L4K 1M8

T : (905) 669-5282  
F : (905) 660-8045

**Aluma Systems  
USA Inc.**  
2915 Sunrise Avenue  
Las Vegas, Nevada  
USA 89101

T : (702) 866-6513  
F : (702) 866-2620

**Aluma Systems  
International, Inc.**  
55 Costa Road  
Concord, Ontario  
Canada L4K 1M8

T : (905) 669-5282  
F : (416) 736-2924