

Aluma Rollback System

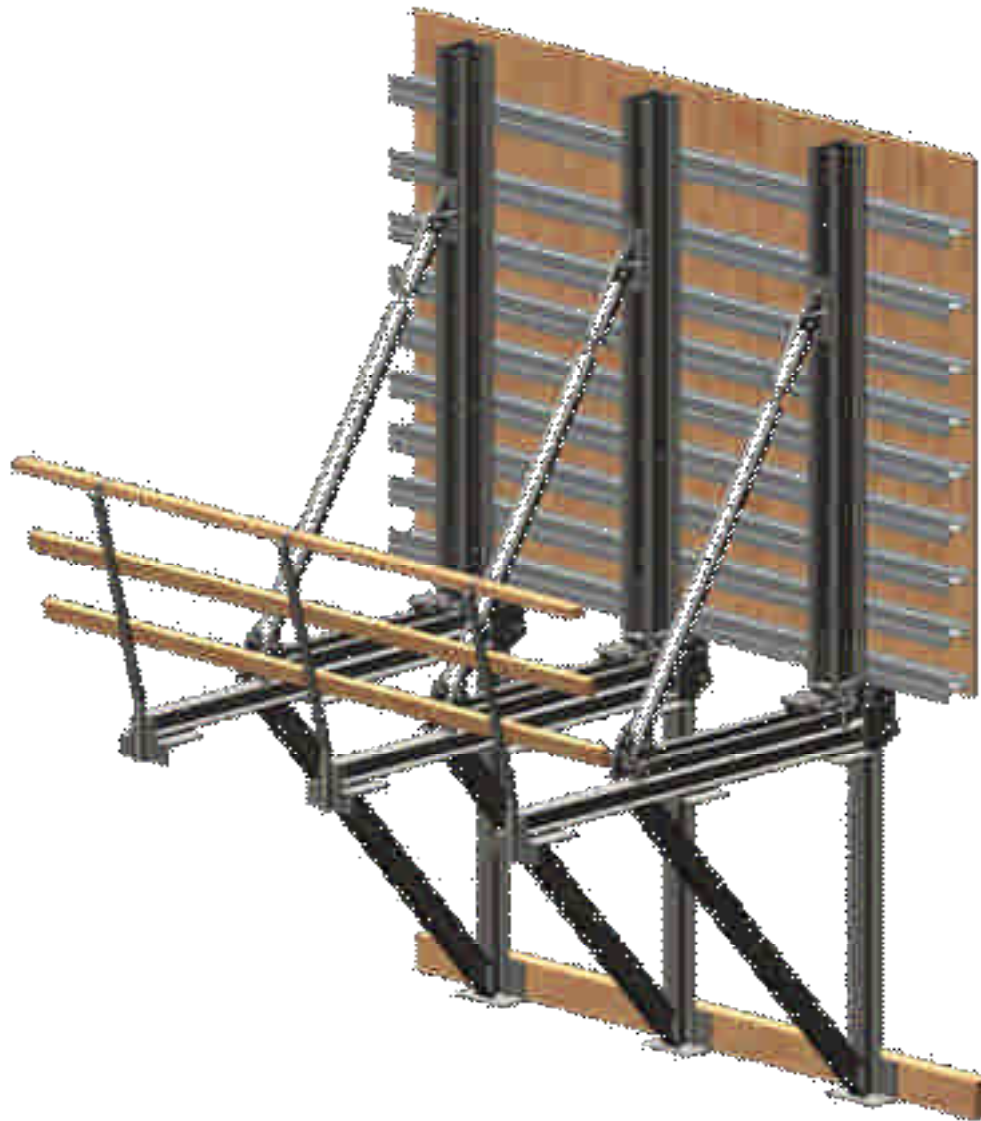

Aluma Rollback System Components



Leveling Bolt Assembly
Item # 7147



Craneset Adaptor
Item # 7187

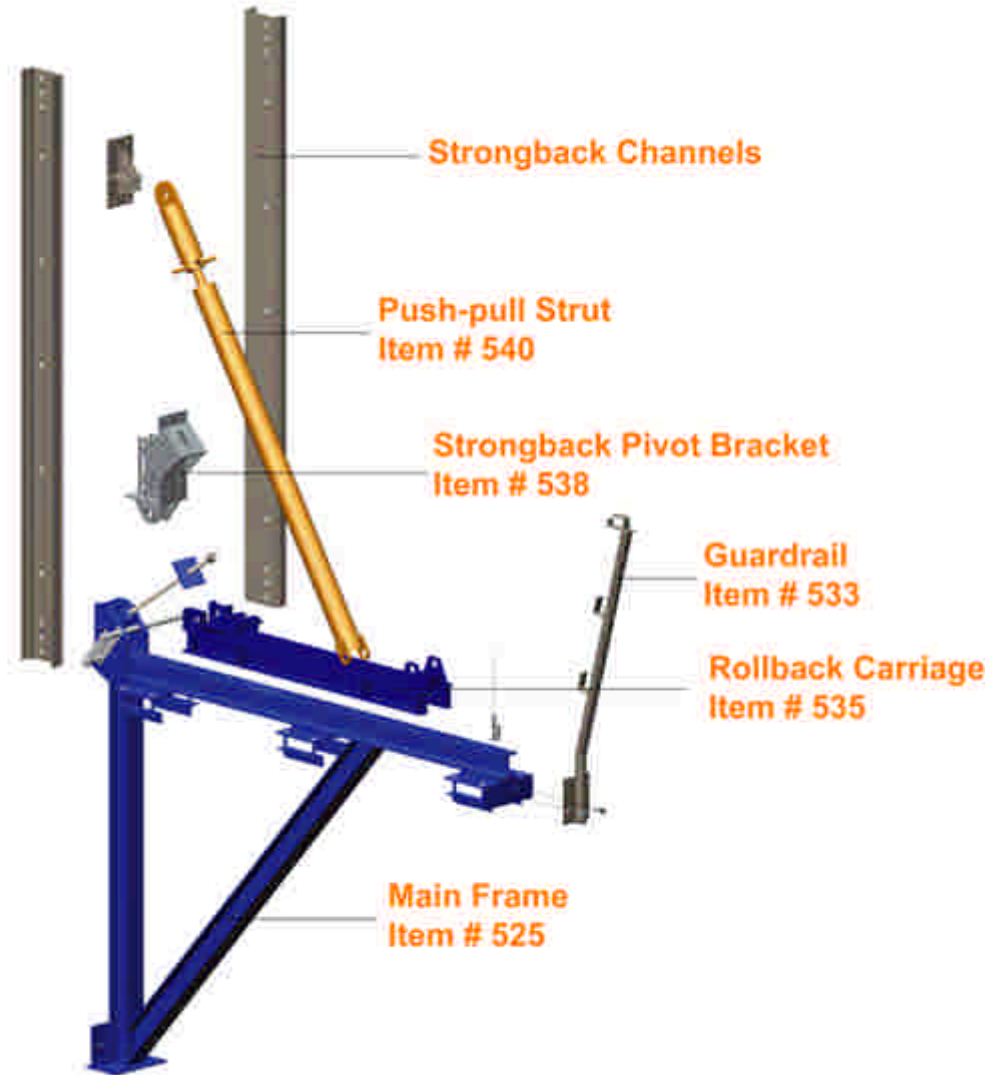

Aluma Rollback System

Features & Benefits

- Can be used with an Aluma Gang, Handset Panels and Steel Walers and Aluma beams.
- Can be used as a platform only, or in combination with wall forms.
- Safe, easy solution to climbing wall forms.
- Wall forms can be easily rolled away from concrete wall 2'-6 by hand
- Includes guardrail post, plumbing brace and leveling bolt.
- Ability to control yaw, pitch and elevation.
- Safely and easily locks bracket to landing bolt with locking pin.
- Positive diagonal tie connection to hold wall form snug to previous pour.
- Various types of landing bolts to suit different conditions.
- Easily connected trailing walers and walkways for finishing concrete wall and removing previous landing bolt
- Few components to order
- High capacity can be used to land a bundle of rebar if designed properly.
- Most parts are easily repaired or replaced reducing damage and loss closeouts with customer.
- 8'-0 wide platform provides plenty of work space.
- Meets all safety codes.